

“Connect & use” glass / dishwasher to suit racks up to 450x450mm



- **Easy-to-use** electromechanical controls with 2 cycles - 60 & 120 seconds
- **Suits all racks up to 450x450mm** - stainless steel grid to support 17x14inch racks
- **Re-circulating & low rinse volume** glass and dishwasher
- **Double skinned door** for strength and durability for loading machine
- Usable chamber height of 285mm
- **Patented** combined polypropylene wash and rinse arm assembly to maximise wash and rinse performance
- Wash pump inlet strainer to ensure machine reliability
- **“Connect & use”**- fill and drain hoses, pump-out drain, chemical dispensers and power lead / plug included for quick and easy installation
- Adjustable rear castors and front feet for easy cleaning
- Includes 1 plate rack & cutlery basket

Technical Data

flexible drain hose 1000mm	Pump-out drain standard
fresh water connection: pressure hose 1000mm	Connection size: 3/4" BSP
flow pressure	200-400kPa
incoming water temperature	55-65°C
power cord	15amp single phase plug & lead
hose for detergent	Included
hose for rinse aid	
wash tank temperature	60-65°C
rinse water temperature (booster tank)	Minimum 82°C
low temp cut-out (thermostop) activated	Yes
cycle times	60 sec. 120 sec.
water consumption	2.9litres @ 200kPa
tank capacity	24 litres
tank heating	2.25kW
power supply	240/50/1 - 15amp
booster loading	2.6kW
total loading	2.8kW
pump capacity	300watts
loading height	285mm

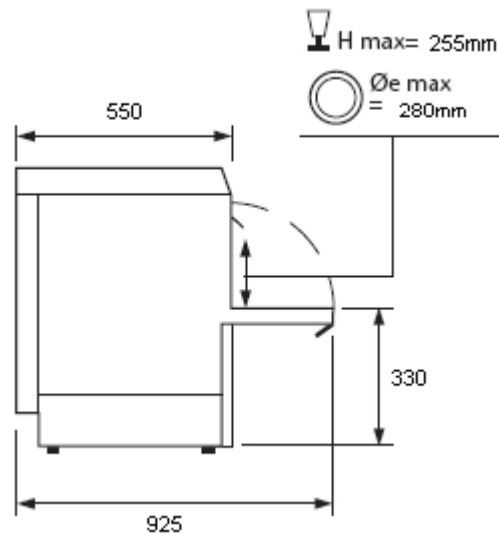

A		Ø 30 mm dia hose
B		Ø 3/4" s/s hose
C		240/50/1

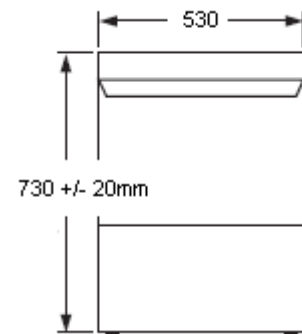

Water hardness should not exceed 3°dH, if higher we recommend using a water softener.

If mineral content is high a demineraliser may be advisable.