

Undercounter dishwasher - up to 40 racks, 720 plates / 1,440 glasses / hour



- **VAPO RINSE ECO:** switchable steam rinse cycle reduces fresh water consumption to 1.6 litre. Saving up to 55% water and detergent as well as up to 70% rinse aid (compared with standard machine)
- **Drying manager PERFECT**
- **Door system VAPOSTOP:** prevents vapour from escaping from the machine when the door is opened
- **Fine filter GENIUS-X²:** advanced filter system with pre-wash function reduces detergent consumption by up to 30%. The HOBART strainer control prevents operation without tank strainer.
- **Significantly lower operational costs by rinse pump ACCURINSE** reduced 2.5 / 1.6* litre rinse, independent of site pressure
- **SMARTRONIC single button operation** with colour coded status and indication of remaining cycle time
- **High quality** rinse aid and detergent dispensers included
- **X-change cycle AQUA-NEW:** selectable wash cycle, drains tank and fills via fresh water rinse. Ideal to wash heavily soiled dishes or for the change of chemicals
- **Wide angle FAN wash nozzles** distribute wash water evenly around the wash chamber
- **Tank heater ECOTHERM:** achieves optimum wash results by maintaining constant wash temperature of 62°C
- **Hygiene program ACTIVE and hygiene tab INTENSIVE:** removes calcium carbonate and other deposits from tank wall
- Can be connected to 415/50/3NE as well as 240/50/1 (standard machine comes with three phase cable)
- **Ready to install.** Includes fill and drain hoses, power cord, non-return valve and drain pump.

Technical Data

① plastic drain hose 2.000 mm	24mm inner / 28mm outer diam.
② fresh water connection: pressure hose 2000 mm flow pressure: water flow required	R 3/4" cap nut 0,5 - 10 bar cold water / hot water max. 65°C 5 l / min.
③ power cord	2000 mm
④ detergent hose	2500 mm
cycle times sec.	90 / 170* 180 / 230* 360 (water X-change) > 360 (endless)
water consumption	2,5 / 1,6* l / rack
tank capacity	10,8 l
tank heating	0,8 kW
voltage	415 / 50 / 3 (240 / 50 / 1)
booster loading	6,1 (2,0) kW
total load 415/50/3 (240/50/1)	7,7 kW (3,6 kW)
wash pump	0,6 kW / 350 l/min.
rack size standard Gastronorm	500 x 500 mm 500 x 530 mm
loading height	425 mm
noise level	63 dB(A)
weight gross / net	75 / 65 kg

¹⁾ To reach set rinse temperatures even with cold water connection, the actual cycle-times extend accordingly.

* with VAPO RINSE ECO steam rinse.

Water hardness should not exceed 3°dH, if higher we recommend using a water softener.

If mineral content is high a demineraliser may be advisable.

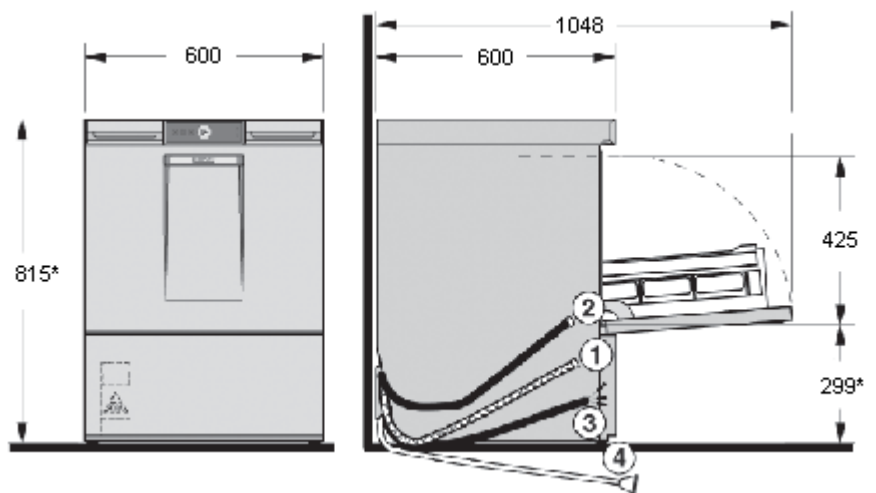

* = + 30mm for adjustable feet