

HOBART

WAREWASHING
UNDERCOUNTER DISHWASHER CARE



Care



As easy to operate as a household dishwasher, the HOBART **Care** offers the benefits of a professional HOBART dishwasher:

- Short washing times
- High-quality finish
- Sturdy design
- Very easy to operate
- Consumption of water, energy and detergents reduced considerably
- Perfect drying result thanks to the integrated TOP-DRY drying
- Reduces steam escape to a minimum

Hygienic cleanliness at a dishwashing temperature of 60 °C - in three minutes flat. There is no faster dishwasher. And if necessary, the wash ware can be **thermally disinfected**. The drying of the wash ware is done by the machine, as well.

TECHNICAL DATA	
Cycle times* in min.***	3/12 and special cycles
Water consumption in l per cycle	3.5 l to 17.5 l/cycle
Tank capacity	10.6 l
Tank heating	1.7 kW
POWER SUPPLY	
Standard	415/50/3N
Alternatives	240/50/1
BOOSTER LOADING	
Standard	6.2 kW
Alternative	3.3 kW
TOTAL LOADING	
Standard	6.8 kW 3 x 15 A
Alternatives	3.3 kW 20 A
Wash pump	0.5 kW (350 l/min)
Rack size	500 x 500 mm
Loading height	425 mm
Noise level	57.7 dB (A)
Weight (gross / net)	70/60 kg

CONNECTIONS	
① Drain hose	2,000 mm ID20 / AD25
② Supply hose	2,000 mm R3/4"
Required flow rate	5 l/min
Flow pressure	0.5 (0.8 with softener - 10 bar)
Max. supply water temperature	60 °C
③ Power cord	2,000 mm
Supply hose for	
④ Detergent	2,500 mm
⑤ Rinse aid	Not in use

PRODUCT ADVANTAGES

- **TOP-DRY drying:** integrated drying technology - no need for manual drying and polishing
- **VAPOSTOP²:** integrated steam condensation allows door opening without steam cloud. Also no steam escape during the condensation phase
- **VISIOTRONIC-TOUCH control:** colour touch screen (displays text and graphic) in conjunction with singlebutton control and remaining cycle time indication
- **WASHSMART app:** controlling your warewash operation with smart technology: status and messages, usage and operating costs, hygiene, service and consumables order
- **2IN1 double rack system:** two racks can be washed in a single wash cycle. One rack of cups can be washed underneath, while a second rack containing dishes and cutlery can be washed above it. Thanks to the optimum use of the entire wash chamber the performance of the machine can be doubled
- **CLIP-IN wash and rinse arms:** wash and rinse arms can be removed with one hand and without any tools
- **Intelligent data documentation:** automatic recording of important operational data and consumptions and indication on the display
- **USB-interface:** comfortable download of operational data in form of a protocol via USB
- **GENIUS-X² fine filter system:** advanced filter system with pre-wash function reduces detergent consumption up to 35%
- **Interlocked strainer:** prevents operation without tank strainer
- **Optional refill signal:** monitors contents of external as well as integrated chemical containers
- **Hygiene programme:** for removal of calcium carbonate and other deposits from wash chamber
- **Optional integrated water softener**
- **Fully equipped and ready to use**

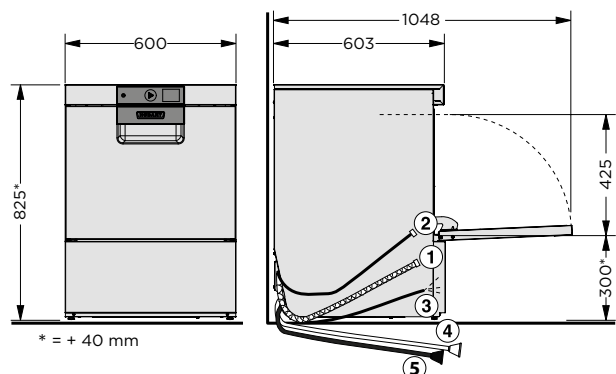

* Thermostat guarantees required temperatures with cold water connection, the actual cycle times extend accordingly. For machine protection the water hardness should not exceed 3°dH, if higher we recommend using an integrated water softener or an external water softener of the product line HYDROLINE PROTECT. To avoid spots and streaks on the wash ware, we recommend the usage of a demineralisation cartridge (HYDROLINE STAR / STAR EXTRA) or a reverse osmosis system HYDROLINE PURE.

** Thermal disinfection programme

*** The machine is equipped with an automatic cycle-time control which ensures hygienic rinse temperatures even on a cold-water supply or with reduced heating performance.